

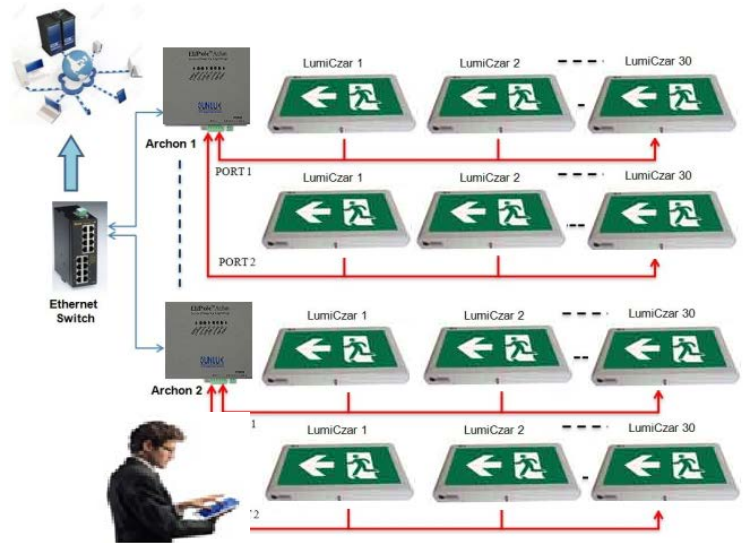

Model: LumiCzar-SS

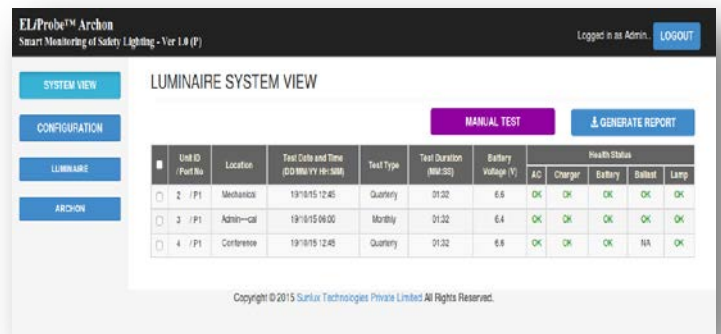

Model: LumiCzar-DS



Web based GUI Software

Features:

- Maintained / Non- maintained Luminaires
- Self-contained
- 2 Watt LED lights to save energy consumption.
- Battery backup up to 3 hours
- User replaceable signage labels.
- Self-test facility with LED indication
- Easy to Add, Delete and Configure via Web based GUI software
- Up to 5 years test data logging facility on-board
- Automatic checking of AC power, battery health, charger health and LED lamps
- Control facility for LED ON/OFF as well as dimming via user friendly GUI Software.
- Performing pre-configured functional test for Monthly, Quarterly and yearly for 90 minutes
- Manually performing a full functional test for 90 second

LED INDICATION



Benefits:

- Reduced Electricity consumption
- Reduced man power requirement to maintain / monitor all lights health status.
- No need of qualified persons and testing tools for manual tests.
- Real time fault indication to reduce time delay for service / repair.
- Easy to generate test reports for safety auditing and maintenance work.
- Replaceable signage labels give freedom to use or relocate the luminaire in any area.

Technical Specifications:

Input voltage	230V AC, 50Hz, 1-ph
Light source	LED (6500K)
Power consumption	2 Watts
Viewing distance	30 meters
Battery	12V Ni-MH Battery
Duration	Upto 3 hours
IP Class	IP20
Weight	LumiCzar-DS: 1150 grams / LumiCzar-SS: 1400 grams
Housing	Sheet metal / Aluminum
Mounting	Wall, Ceiling, and Suspended mount (option: Recessed mount)

Warranty:

One year standard warranty on all products.

Note: Signage labels and enclosure are not covered under warranty terms.

Dimensions:

LumiCzar-DS

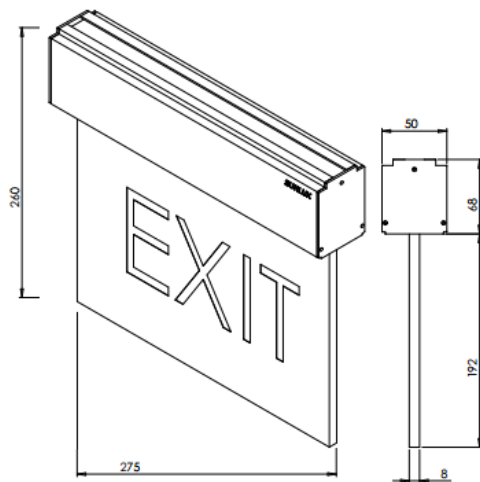

LumiCzar-SS

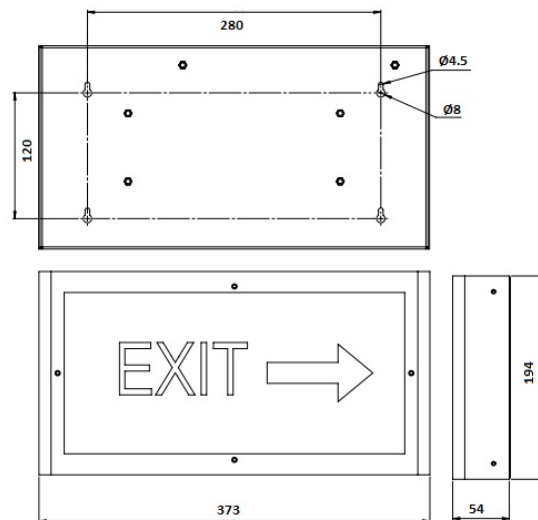

Ordering Information:

Model	Features	Code	Standard Labels	Code	Mounting	Code	Type	Code
1. LumiCzar-SS	Basic Model	BM	EXIT	E	Wall	W	Maintained	M
	Self-Test	ST	EXIT LEFT	EL	Ceiling	C	Non maintained	NM
2. LumiCzar-DS	Remote monitoring	RM	EXIT RIGHT	ER	Side	S		
			EXIT UP	EU	Hanging	H		
			EXIT DOWN	ED	Recessed	R		
			CUSTOM	C				

Example order code: LumiCzar-SS-ST-E-W-M

Note: Customize labels: Please provide the signage label details

Accessories:

Extra signage labels (standard and customer specific)



Contact us:

SUNLUX TECHNOVATIONS PVT LTD

#174, Second Floor, Anugraha, 19th Main Road, 4th Sector, HSR layout, Bangalore - 560102

Phone: 080-69000510/513 / 080-65954374

Email: muthu@sunluxtechnovations.com. Web: www.sunluxtechnovations.com,